

DC-AC INVERTER UNIT

PS-DA0288-02-x (S) (8 W DUAL OUTPUTS)

(PRELIMINARY INFORMATION)

DESCRIPTION :

This low profile DC to AC Inverter is developed for dual lamps. Many different output connector possibilities will make this Backlight Inverter so flexible.



APPLICABLE LCD:

- 5.7 to 12 inches double lamp type
- Lamp Voltage 375 Vrms
- Lamp Current 5 mArms
- Lamp Start Up Voltage 1.500 Vrms (Vin : 5 Vdc)

FEATURES :

- Remote ON/OFF
- Dimming with analogue voltage or by resistor dimming
- RoHS compliant (S)
- Alarm-signal-function
- Different models (see order key)

TEMPERATURE & HUMIDITY :

- Operating Temperature Range -10°C ~ +60°C
- Storage Temperature Range -20°C ~ +85°C
- Humidity 95 %RH max

DIMENSIONS :

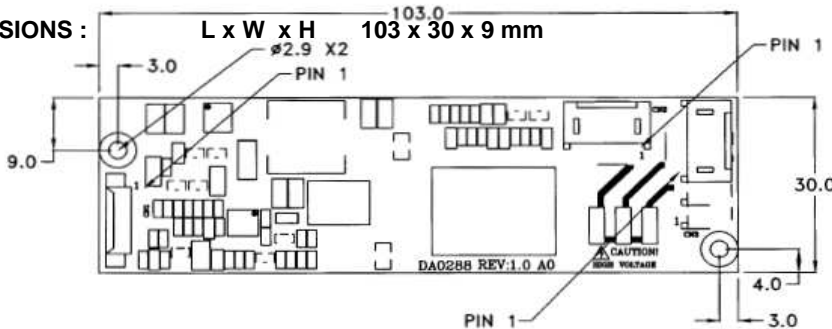

Unit : mm
Weight :20 (g) typ.

Components

No.	Part Description	Qty.	Material	Note
1	PCB	1	FR4; UL94V-0	t=1.0mm
2	Connector CN1	1	53261-0890	MOLEX
3	Connector CN2, CN3	1	SM02(8.0)B-BHS-1-TB	JST or equal

Input side CN1:

Pin No.	Symbols	Ratings
CN 1-1	Vin	4.5~5.5V
CN 1-2		
CN 1-3	GND	0 V
CN 1-4		
CN 1-5	Vrmt	0~0.4V=OFF / 2.5V~Vin=ON
CN 1-6	Vbr/Rbr	0~2.5V / 0~10kΩ
CN 1-7	Vbr/GND	0 ~ 10kΩ
CN 1-8	Vst	0V / 3V (Note 3)

Output side CN2

Pin No.	Symbols	Ratings
CN 2-1	Vhigh	375Vrms
CN 2-2	NC	-
CN 2-3	Vlow	0Vdc

Output side CN3

Pin No.	Symbols	Ratings
CN 3-1	Vhigh	375Vrms
CN 3-2	NC	-
CN 3-3	Vlow	0Vdc

Power Systems – The Power Solution

Web: www.Power-Systems.de
Email: Info@Power-Systems.de

Address: Hauptstr. 48 ; 74360 Ilsfeld-Auenstein / Germany
Tel. : + 49 / 70 62 / 67 59 - 6
Fax: + 49 / 70 62 / 67 59 - 800

DC-AC INVERTER UNIT

PS-DA0288-02-x (S) (8 W DUAL OUTPUTS)

(PRELIMINARY INFORMATION)

ELECTRICAL CHARACTERISTICS :

Parameters	Symbols	Conditions			Specification			Unit	Note
		Vin (V)	Vrmt (V)	Tu (°C)	Min.	Typ.	Max.		
Output Current (Brightness max.)	Iout1/2	5±0.05	5±0.25	-10~+60	4.5	5.0	5.5	mArms	
Output Current (Brightness min.)	Iout1/2	5±0.5	5±0.25	-10~+60	1.7	2.4	3.1	mArms	Vbr = 2.5 Vdc / Rbr = 10KΩ
Input Current	Iin	5±0.5	5±0.25	-10~+60	-	1.49	1.94	A	Vin 5V
Frequency	F	5±0.5	5±0.25	-10~+60	34.5	42.0	49.5	kHz	
Open Circuit Voltage	Vopen	11.4 min.	5±0.25	-10~+60	1300	1500	1700	Vrms	
Shutdown		5±0.5	5±	-10~+60	-	1	-	Sec.	
Alarm Signal	Vst	5±	5±	-10~+60	4.5	5.0	5.5	Vdc	CCFL-fail

- Note 1 : Please keep minimum of 2mm clearance (all directions) between inverter high voltage area as marked on mechanical drawing and any conductors.
- Note 2 : Before apply any control signal into inverter, please provide Vcc first. Please follow the reversed sequence during power off. Power off control signal first, then power off Vcc.
- Note 3 : This is an output pin and it is active high (+3V) if any Lamp opens / fails.

TEST CIRCUIT :

PS-DA0288-02-1

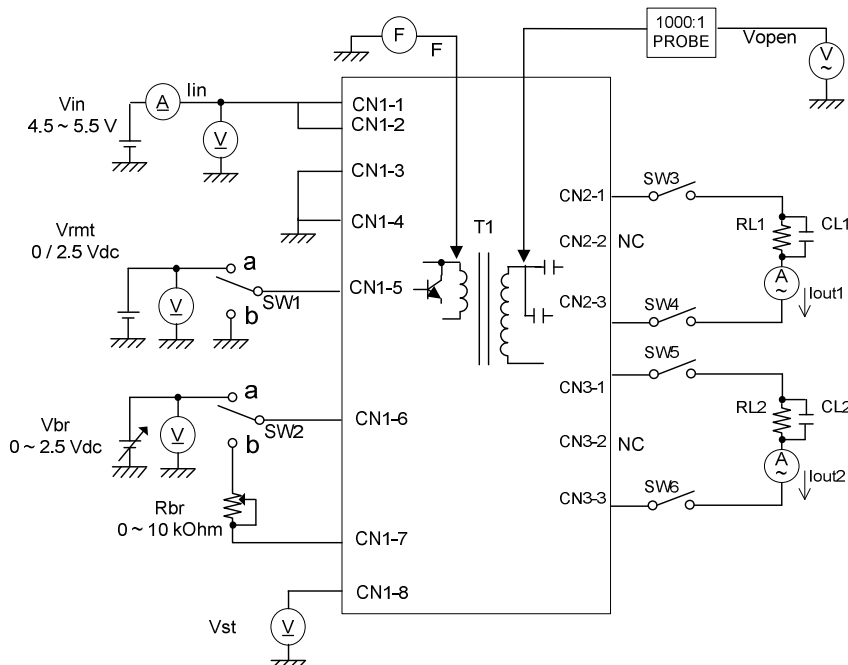

SW1	Operation of unit
a	Operation
b	Non operation

Power Systems – The Power Solution

Web: www.Power-Systems.de
 Email: Info@Power-Systems.de

Address: Hauptstr. 48 ; 74360 Ilsfeld-Auenstein / Germany
 Tel. : + 49 / 70 62 / 67 59 - 6
 Fax: + 49 / 70 62 / 67 59 - 800

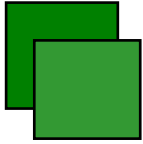

CONNECTOR/PINNING/ORDER KEY :

Model	Connector	Pinning	Vin	Connector	Pinning	
					CN2	CN3
DA0288-02-1	2x SM02(8.0)	1=H, 2=N.C, 3=L	5V	CN2+CN3	1;3	1;3
DA0288-02-2	2x SM02 B-BHSS	1=H, 2=L	5V	CN2+CN3	1;2	3;4
DA0288-02-3	1x SM03(4.0)	1=L, 2+3=H	5V	CN3		1;2;3
DA0288-02-4	1x SM03(4.0)	1+2=H, 3=L	5V	CN3		2;3;4
DA0288-02-5	1x SM04(4.0)	1+2=H, 3=N.C, 4=L	5V	CN3		1;2;3;4

TEST CIRCUIT :

PS-DA0288-02-2

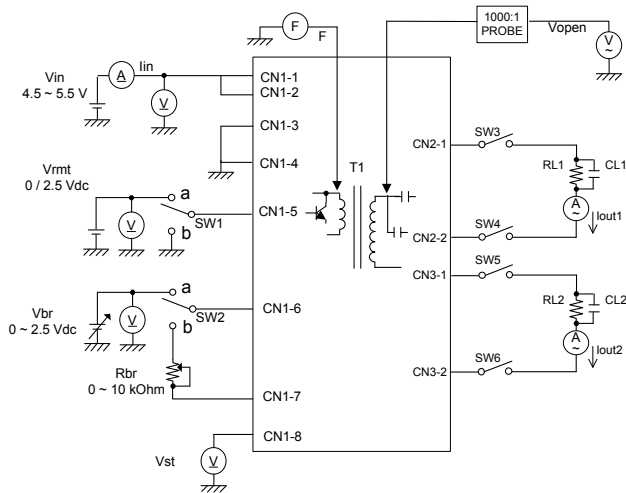

PS-DA0288-02-3

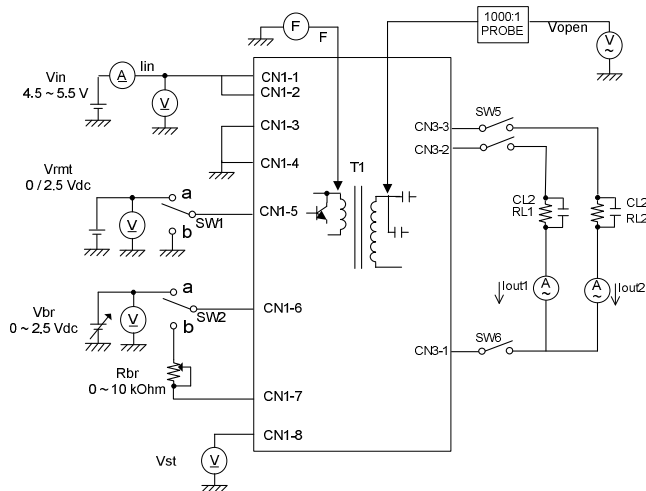

Power Systems – The Power Solution

Web: www.Power-Systems.de
 Email: Info@Power-Systems.de

Address: Hauptstr. 48 ; 74360 Ilsfeld-Auenstein / Germany
 Tel. : + 49 / 70 62 / 67 59 - 6
 Fax: + 49 / 70 62 / 67 59 - 800

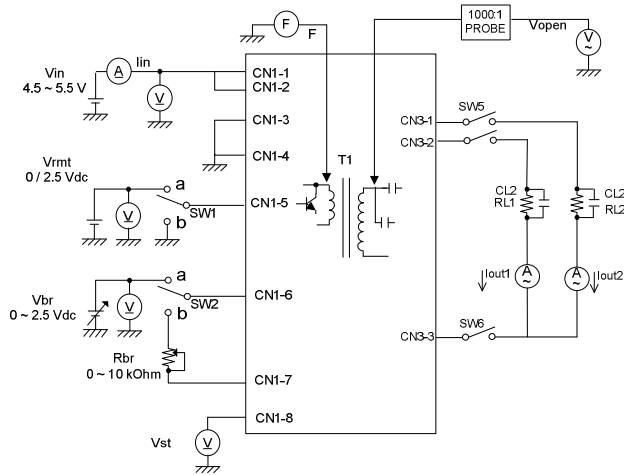
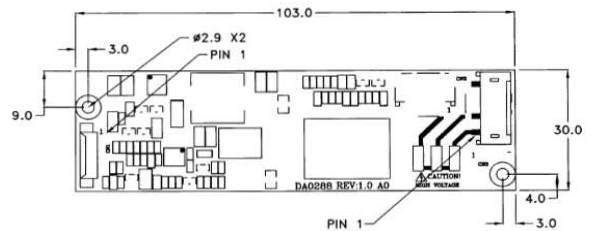
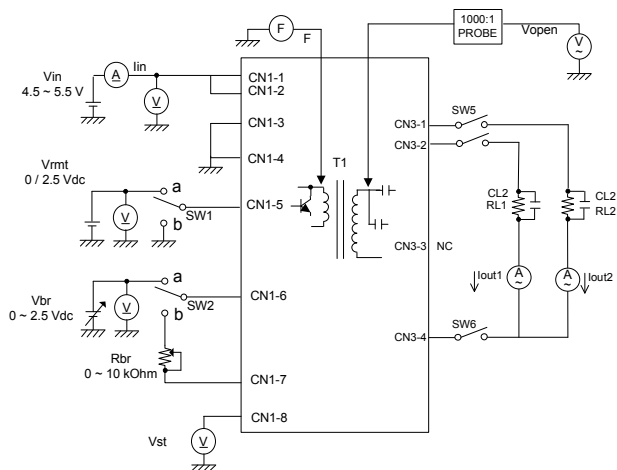
PS-DA0288-02-4

PS-DA0288-02-5

Power Systems – The Power Solution

Web: www.Power-Systems.de
 Email: Info@Power-Systems.de

Address: Hauptstr. 48 ; 74360 Ilsfeld-Auenstein / Germany
 Tel. : + 49 / 70 62 / 67 59 - 6
 Fax: + 49 / 70 62 / 67 59 - 800