

DC-AC INVERTER UNIT

PS-DA0253-11(S) (9 W DUAL OUTPUTS)

(PRELIMINARY INFORMATION)

DESCRIPTION :

This DC to AC Inverter was developed for many other low LCD Backlight power supply as low profile applications, either for LCD Monitor or Industrial PC.

APPLICABLE LCD:

- 10 to 15 inches dual lamp type
- Lamp Voltage 600 Vrms
- Lamp Current 2 x 6.0 mArms
- Lamp Start Up Voltage 1.400 Vrms (Vin : 5 Vdc)

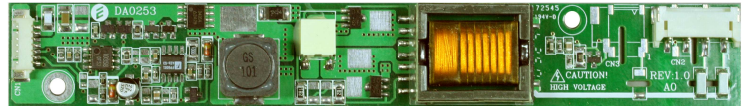

FEATURES :

- Current Feedback Circuit
- High Efficiency
- Low noise with voltage resonant circuit
- Regulated output current
- RoHS compliant (S)

TEMPERATURE & HUMIDITY :

- Operating Temperature Range 0°C ~ +50°C
- Storage Temperature Range -20°C ~ +85°C
- Humidity 95 %RH max

DIMENSIONS :

L x W x H 153 x 21.5 x 10 mm

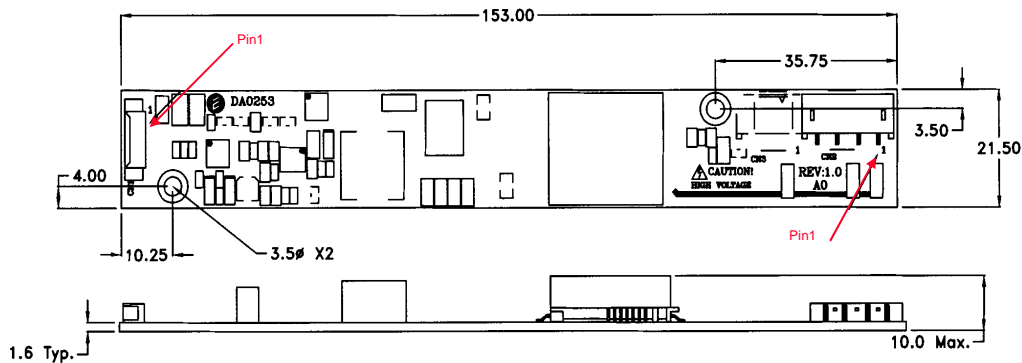

Unit : mm
Weight :40 (g) typ.

Components

No.	Part Description	Qty.	Material	Note
1	PCB	1	UL94V-0 (FR-4 or CEM-3)	t=1mm
2	Connector CN1	1	53261-0790	Molex or equal
3	Connector CN2	1	SM04(4.0)B-BHS-1-TB	JST or equal

Input side CN1:

Pin No.	Symbols	Ratings
CN 1-1+2	Vin	4.75 ~ 5.25 Vdc
CN 1-3+4	GND	-
CN 1-5	Vrmt	0 ~ 0.4 = OFF / 2.5 ~ Vin = ON
CN 1-6	Vbr	0 ~ 5.0 Vdc
CN 1-7	GND	-

Output side CN2

Pin No.	Symbols	Ratings
CN 2-1	Vhigh	600 Vrms (6.0 mArms)
CN 2-2	Vhigh	600 Vrms (6.0 mArms)
CN 2-3	N.C.	-
CN 2-4	Vlow	(GND)

Power Systems – The Power Solution

Web: www.Power-Systems.de
Email: Info@Power-Systems.de

Address: Hauptstr. 48 ; 74360 Ilfeld-Auenstein / Germany
Tel. : + 49 / 70 62 / 67 59 - 6
Fax: + 49 / 70 62 / 67 59 - 800

ELECTRICAL CHARACTERISTICS :

Parameters	Symbols	Conditions			Specification			Unit	Note
		Vin (V)	Vbr (V)	Tu (°C)	Min.	Typ.	Max.		
Output Current	Iout	5±0.25	0.0	0 ~ +50	5.5	6.0	6.5	m Arms	Duty 100%
Output Current	Iout	5±0.12	5.0	0 ~ +50	1.5	2.2	2.9	m Arms	
Input Current	Iin	5±0.25	0.0	0 ~ +50	-	1.72	2.25	Adc	
Frequency	F	5±0.25	0.0	0 ~ +50	39.0	46.5	54.0	kHz	
Open Circuit Voltage	Vopen	5±0.25	0.0	0 ~ +50	1.300	1.400	1.700	Vrms	
No Load Shutdown	Tsd	5±0.25	0.0	0 ~ +50	-	1.0	-	SEC	without load

Note 1 : Please keep minimum of 2mm clearance (all directions) between inverter high voltage area as marked on mechanical drawing and any conductors.

DIMMING CHARACTERISTICS (Reference)

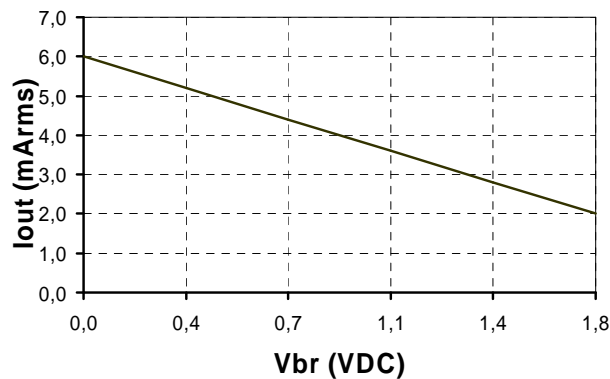

TEST CIRCUIT :

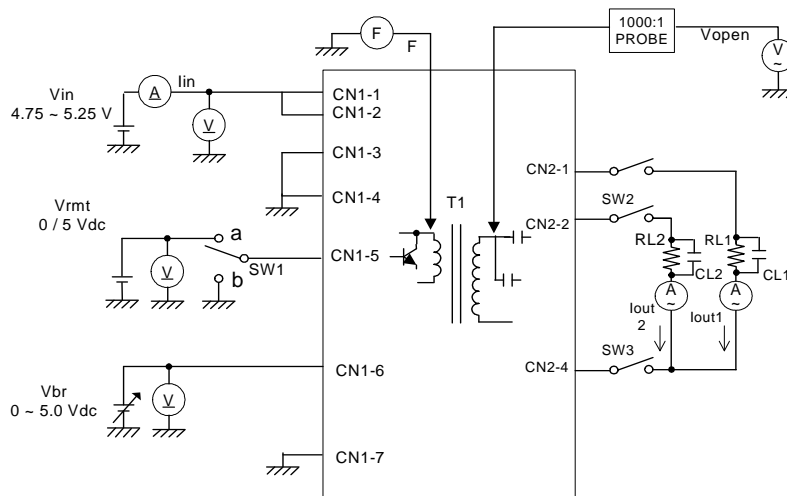

SW1	Operation of unit
a	Operation
b	Non operation

Power Systems – The Power Solution

Web: www.Power-Systems.de
 Email: Info@Power-Systems.de

Address: Hauptstr. 48 ; 74360 Ilsfeld-Auenstein / Germany
 Tel. : + 49 / 70 62 / 67 59 - 6
 Fax: + 49 / 70 62 / 67 59 - 800